

CHANDLER 30 PTT-FT EXW FERTILIZER AND LIME SPREADER



- 16,000 # Tandem Torsion Axles
- 700/40 – 22.5 Floatation Tires
- Wider Spread Patterns
70' Fertilizer
50' Lime
- Mesh Type Chain or Optional
Belt-Over Bar

- Dished Type Spinners Designed for
Maximum Coverage on Spread Pattern
- Tandem Pump System with 50-Gallon
Hydraulic Oil Tank
- Control Systems available from Raven
Industries



The 30 PTT-FT-EXW is the latest in the EXW line. This spreader has the same dependability, accuracy and reliability that Chandler Spreaders have been known for over the past forty years. This spreader is truly in a class by itself with *our exclusive 16,000 # torsion axles*, floatation tires, and wider spread patterns. Designed for the grower/applicator that is not yet ready to step up to a big self-propelled floatation machine but already has 200-300 HP tractors on their farm and needs something bigger than your average pull type spreader.

This spreader has a capacity of 10-ton Fertilizer and 12-ton Lime with application rates from 50 # per acre to over 800 # per acre on fertilizer and from 500# to over 4 Tons per acre on lime with ground speeds up to 14 mph.

To learn more about our EXW line of spreaders contact Chandler Equipment or your nearest dealer.

andler Equipment Co.

Gainesville, Georgia 30503 – 770-536-8891
Toll Free 1-800-243-3319, 770-535-1265 Fax
www.chandlerequipment.net

Chandler 30 PTT – FT EXW

Specifications

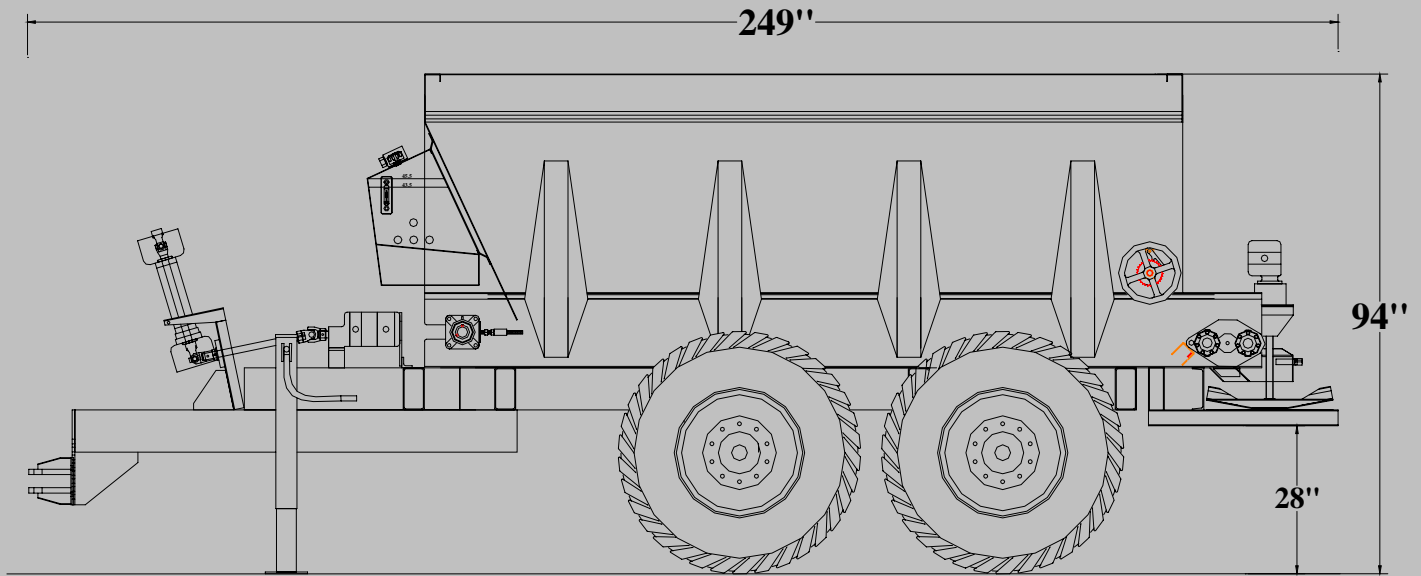

| | Fertilizer @ 65 # | Lime @ 90 # |
|--------------------------------------|-------------------|-------------|
| Hopper Capacity (Struck Level) | 280 Cu. Ft. | |
| Payload (struck level)..... | 18220 Lbs. | 24,000 Lbs |

Spread Patterns:

Fertilizer up to 70'

Lime up to 50'

| | |
|-----------------------------------------|-----------------------------|
| Hopper Capacity (Heaped & Tarped) | 310 Cu Ft. |
| Payload (Heaped) | 20,150 Lbs.28,000 Lbs. |

All Products and Specifications subject to change without notice. Drawing shown with 45 - degree slope sides and 24"Mesh Type Chain.



Hopper Construction:

Available in three types of material: Mild Steel, 409 Stainless Steel, and 304 Stainless Steel

Conveyor Specs:

Available in three types: 24" - 1" x 1" Mesh Type-304 Stainless Steel, Bar Type Chain and Belt Over – Bar type Chain

Spinner Specifications:

Four blade configuration spinners and a specially designed flow divider for wide swath applications. (50' Lime – 70' Fertilizer) High Pressure, Double Bearing spinner motors mounted overhead keeps motors out of fertilizer and other contaminants for longer life.

C

handler Equipment Co.

Gainesville, Georgia 30503 – 770-536-8891
 Toll Free 1-800-243-3319, 770-535-1265 Fax
www.chandlerequipment.net